

VA51/52

Line Scan Vision Appliance



VA51/52

Key Features

- Cost-effective multi-camera solution
- Choice of camera type and resolution
- Powerful embedded processor ensures fast inspection times
- Rugged system for online or offline inspection
- Universal solution for end users, integrators and machine builders

Vision Capabilities

- Positioning
- Identification
- Verification
- Measurement
- Flaw Detection

Overview

Line Scan Vision Appliances

Teledyne DALSA's VA5X Vision Appliances are compact machine vision controllers for automated optical inspections that use line scan camera technology. These products have been designed for applications requiring cylindrical unwrapping of parts or large format imaging of moving surfaces.

Multiple camera inputs provide cost efficiency and easier integration for applications that need to perform simultaneous inspection on more than one part or process. The VA5X products support a range of camera resolutions from 1024 to 8096 pixels and provide synchronization timing between the cameras and the moving part or surface

Communication options include standard serial and Ethernet interfaces for communicating with complementary devices or connecting into the factory network.

Specifications

	VA51	VA52
Program Memory	1 GB	3 GB
Storage Memory	80 GB	320 GB
# Cameras	2 line scan	2 line scan
Camera Interface	Camera Link	Camera Link
Communication		
- Ethernet	10/1000	10/100/1000
- USB	2 (2.0)	2 (2.0)
- Serial	RS-232	RS-232
- Visual	7 LEDs	7 LEDs
I/O	24V 12in/8out	24V 12in/8out
User Interface	Sherlock	Sherlock
Mono/Color Processing	Mono or Color	Mono or Color
Power	24V @ 2.5A	24V @ 2.5A
Operating	0-40°C ambient, 5-90% humidity	0-45°C ambient, 5-90% humidity
Dimensions	7.6 x 20 x 21.5 cm	7.6 x 20 x 21.5 cm
Approvals	CE	CE

VA51/52

Line Scan Vision Appliance

The VA5X is pre-loaded with our distinct application interface, Sherlock. This windows-based graphical design environment provides a comprehensive suite of tools and capabilities to satisfy a variety of applications and industries.

Sherlock supports standard factory protocols, such as Modbus and Ethernet/IP, for connecting with complementary equipment.

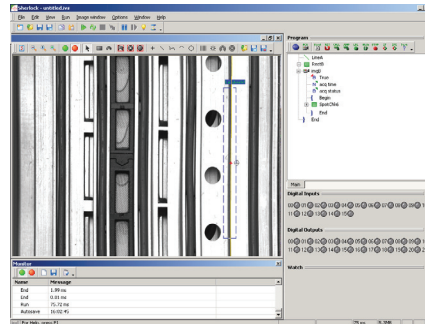

Designed for All Users

Sherlock software offers experienced integrators flexibility and advanced capabilities to tackle the most demanding applications. Sherlock has been deployed in thousands of applications worldwide.

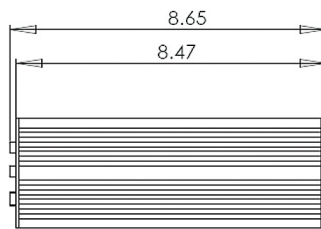

Side View

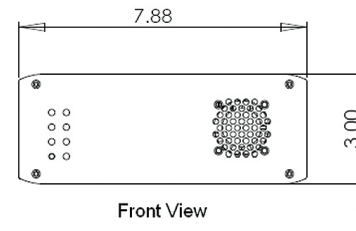

Front View

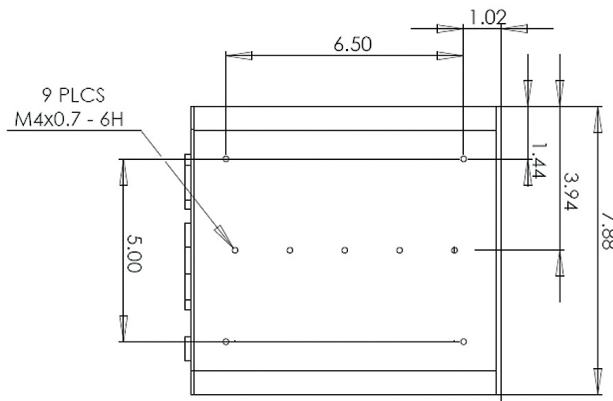

Bottom View

VA51/52 Dimensions

All dimensions in inches

www.teledynedalsa.com

Americas

Boston, USA
+1 978-670-2000
sales.americas@teledynedalsa.com

Europe

Munich, Germany
+49 8142-46770
sales.europe@teledynedalsa.com

Asia Pacific

Tokyo, Japan
+81 3-5960-6353
sales.asia@teledynedalsa.com

Shanghai, China
+86 21-3368-0027
sales.asia@teledynedalsa.com